

## The foundation's agreement with the Associazione Marco Fanno

On July 18, 2012 UniCredit & Universities signed an agreement with the Associazione Marco Fanno, which will enhance the foundation's work for years to come. By joining forces, the foundation and the association will strengthen their support for education and research both qualitatively and quantitatively, in terms of the number of initiatives to be launched.

The foundation and the association finalised their agreement following three years of discussions. This lengthy period of negotiations allowed both parties to carefully consider all available strengths and to develop the best means for implementing their work.

The Associazione Marco Fanno concentrates its efforts on promoting and maintaining contacts and on contributing to the development of cultural events and scientific initiatives in the fields of economics and finance. The foundation's Board of Directors will evaluate all proposed initiatives and provide organisational and financial support for their implementation. With the foundation's support, the association will serve as a dynamic think-tank focused on economics and finance.

The foundation will provide the association with organisational support, including venues for such activities as its assembly and board meetings. More importantly, the association's think-tank will receive a steady stream of new members each year from the winners of the Marco Fanno Scholarship and of the foundation's other scholarships, fellowships and research grants.

The foundation is committed to offering awards, scholarships and fellowships and to developing and supporting academic initiatives that bear Marco Fanno's name, to upholding and enhancing the heritage of the Associazione Marco Fanno. Depending on the available resources, the agreement also authorises the foundation to launch at least one Marco Fanno Scholarship every year and other possible initiatives, such as grants or fellowships honoring Marco Fanno or Franco Modigliani.

The launch of 2012 Marco Fanno Scholarship was the first major result of the agreement. This revived a prestigious tradition, which had been put on hold for several years.

The extent of UniCredit & Universities' collaboration with the Associazione Marco Fanno is further demonstrated by the association's permanent seat on the foundation's Board of Directors as well as two positions on its Scientific Committee.

For UniCredit & Universities, the agreement is an achievement and a testament to its ability to support study and research at international level. Moreover, it speaks for the foundation's organisational capacity to face new challenges and expand its responsibility, in this case to the Associazione Marco Fanno alumni.

Finally, this agreement responds to the increasing difficulties affecting the framework in which both organisations operate. Their cooperation will enhance their work and skills, and create synergies that deliver greater value to students and researchers than would be the case if the foundation and association worked independently.



From the left: **Franco Bruni**, Chairman of the Scientific Committee of UniCredit & Universities Foundation and an Alumnus Fanno, **Dieter Rampl**, Chairman of the UniCredit & Universities Foundation, e **Michele Salvati**, Chairman of the Marco Fanno Association.

## Appointment of the Board of Directors of UniCredit & Universities Foscolo Foundation

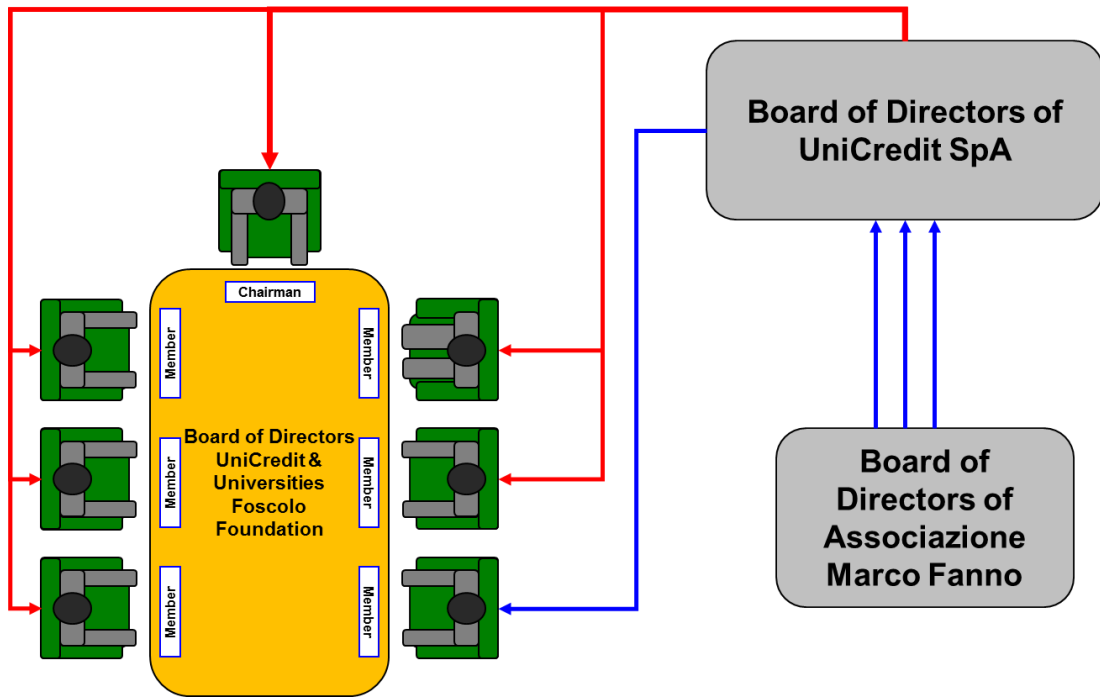

## Appointment of the Scientific Committee of UniCredit & Universities Foscolo Foundation

